

BASCO TYPE OP HEAT EXCHANGERS

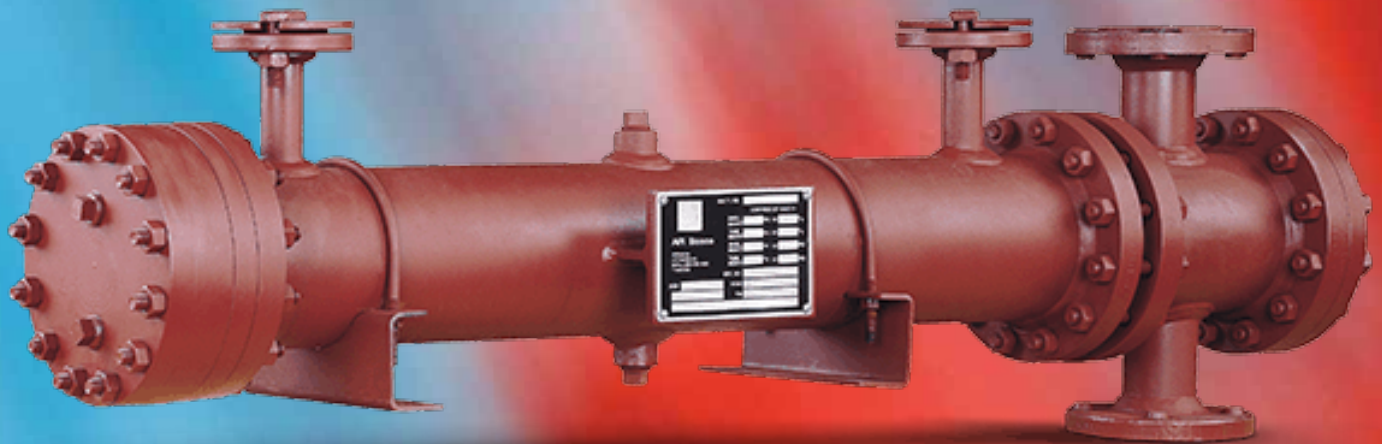

API Heat Transfer Tradition Ensures Quality

Quality, Value and Performance. An API Heat Transfer Tradition.

For over 58 years, original equipment manufacturers and aftermarket providers have looked to us for a wide variety of heat transfer products. The Basco® Type OP optimizes standardized components in a highly configurable design for a wide variety of process applications. OP designs can be modified to include TEMA-C, B or R and stacked for duplex cooler arrangements.

Standard Heat Exchanger Designs Deliver Cost Effective Performance.

First introduced in 1962, the Basco OP design has proven to be the preferred TEMA Type AEW and BEW shell and tube heat exchanger in the market. The OP, or O-ring Protected design, is available in single or dual pass. It features removable tube bundle, nozzle location flexibility, and a uniquely threaded O-ring retainer that permits removal of the reversing bonnet without disturbing the piping or draining the shellside fluid. Removal of the channel cover permits full inspection and cleaning of the tubeside.

The unique O-ring retainer prevents the possibility of over-tightening the bolts and damaging the O-rings. This same retainer incorporates two telltale holes that warn the operator of any fluid leaks from either the shell or tubeside. API Heat Transfer has standardized this design using stock components. This means the solution to your cooling requirement is closer than ever.

Quality

At API Heat Transfer, quality begins with properly applying the design to the process conditions, ensuring the design of the heat exchanger is mechanically correct for the service and applicable code requirements, and finally manufacturing the unit to strict quality standards using only high-quality code materials. The Basco OP has a proven track record for quality and service.

- Knowledgeable Application Engineers can design and price most of your heat exchanger requirements within hours of your request.
- ASME, API 614, ABS, USCG and other constructions are available.

Value

Value means obtaining the best features and performance required to meet a particular need at the best price and lead time. API Heat Transfer knows this and has designed the Basco OP to exceed your expectations.

- Unique double O-ring sealed floating heads provide leak detection and eliminate the possibility of over-tightening bolts, avoiding damage to the O-rings.
- Dome type shell nozzles are available for higher flow rates at lower pressure drops.
- Highly efficient heat transfer is achieved using tight manufacturing tolerances that minimize fluid bypass with either bare or low-finned tubes.
- Flexible configurations all manufactured from stock components ensure proven designs in the shortest possible lead time.

Performance

The wide range of OP configurations available have made these durable performers the first choice for a variety of cooling applications including:

- Compressed air
- Steam or gas turbine oil
- Hydraulic oil
- Lube oil
- Bearing water
- Jacket water
- Gland seal condensers
- Condensate cooling
- Ship board and marine engines

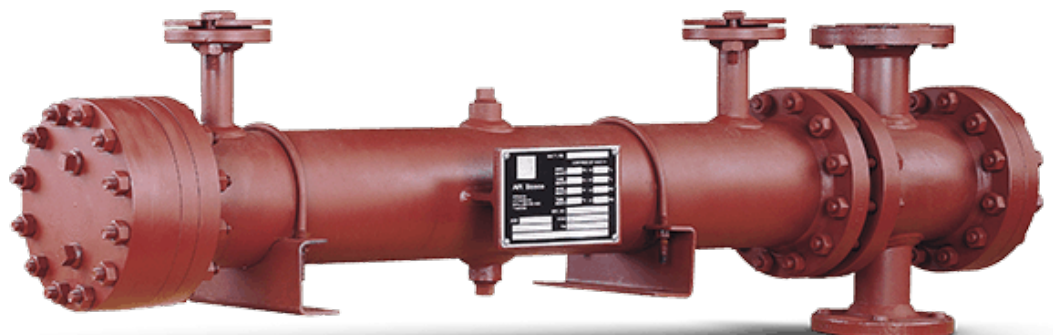

OP Exchanger Design Technology

Basco Type OP Heat Exchanger

Offers cost-effective performance by utilizing standardized designs and stock components.

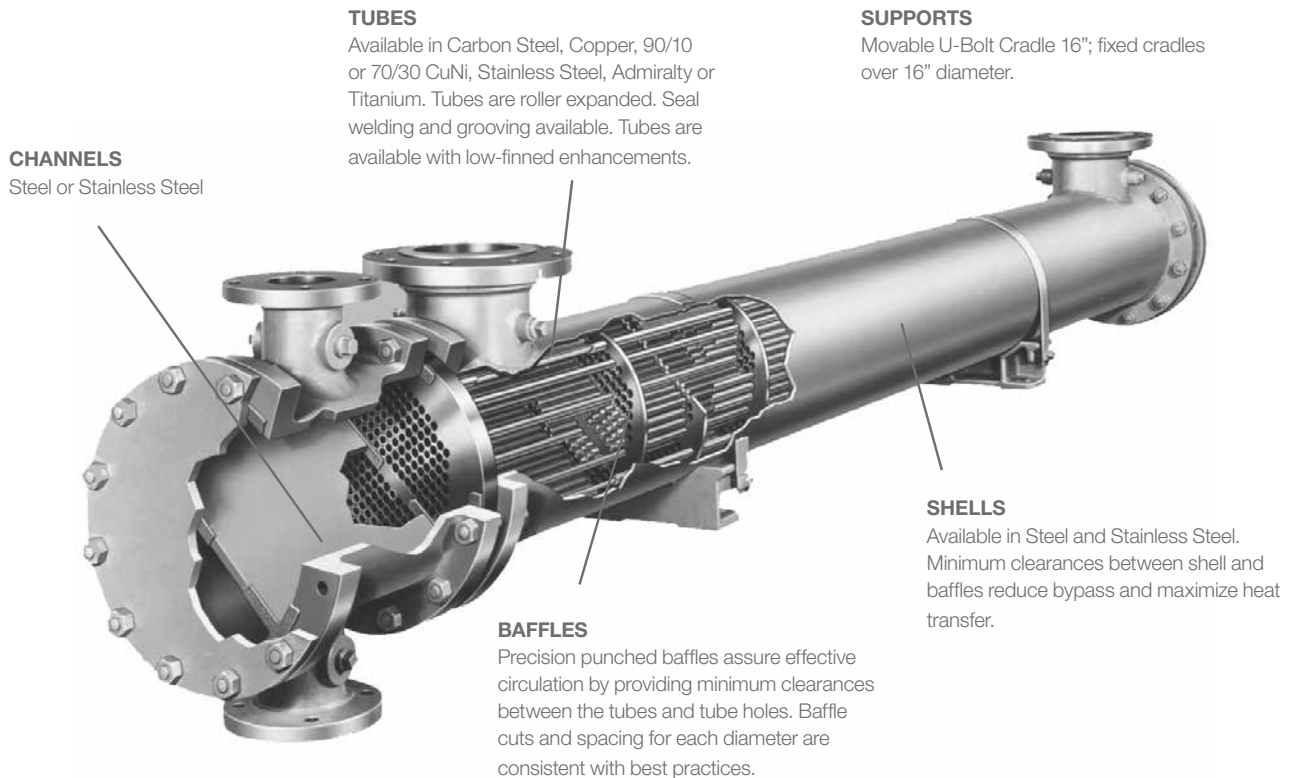

Basco's Double O-Ring Seal Protection

Permits tube bundle to expand and contract without strain or intermixing of shell and tubeside fluids. O-Rings retain compression and are unaffected by vibration and temperature changes. Telltale holes reveal any leakage.

Special Feature

The unique construction of the Basco OP permits inspection and maintenance of the tubeside without draining the shellside or disturbing the piping.

O-Ring Retainer

Every other bolt hole is tapped, permitting removal of channel or bonnet without disturbing retainer or internal packing

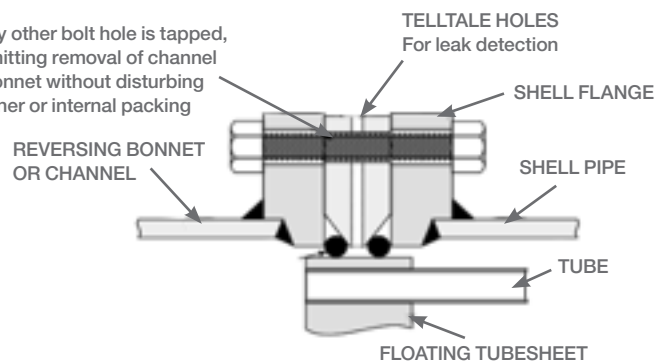

Standard Design Pressures & Temperatures

		Design Press.		Test Press.	Design Temp*	
Shellside	All models	150 PSI	10.5 BAR	per code	300°F	149°C
Tubeside	3"–18" models	150 PSI	10.5 BAR	per code	300°F	149°C
	20"–42" models	75 PSI	5.3 BAR	per code	300°F	149°C

Complies with ASME-TEMA "C", AEW design. USCG, ABS and TUV approved.

* Nonferrous tube sheets designed for 300°F mean metal temperature. Higher design pressures and materials of construction are available upon request.

Single Pass Type OP Heat Exchangers

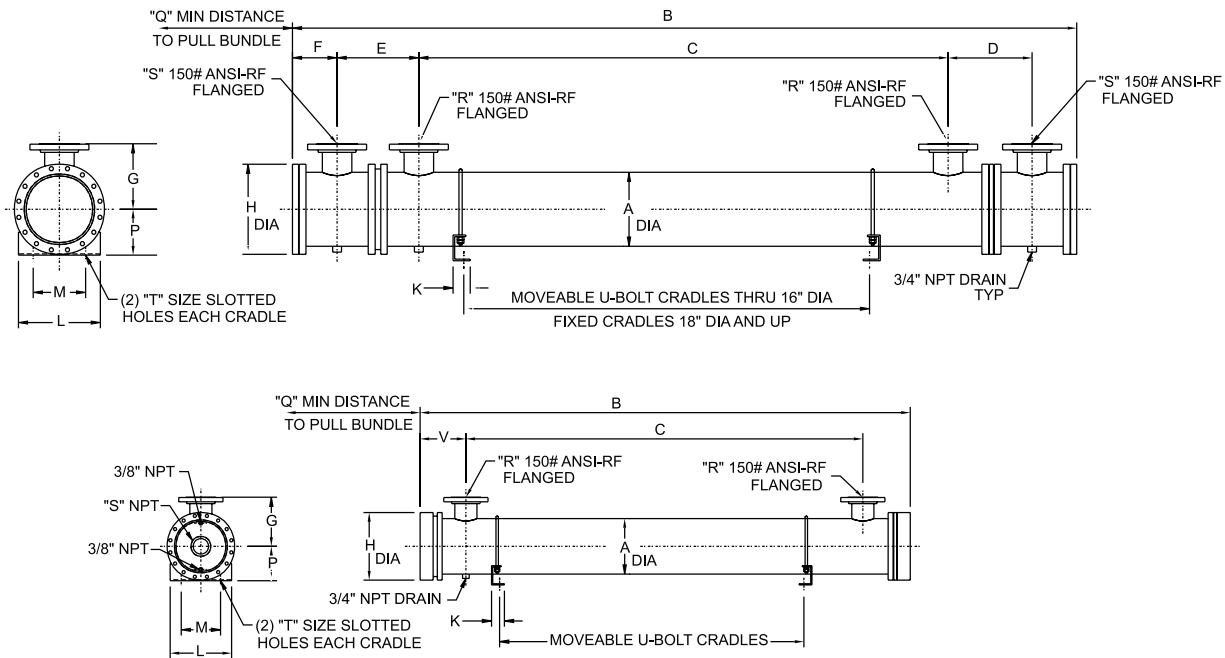

Model	A	B	C	D	E	F	G	H	K	L	M	P	Q	R	S	T	V
03120	3 1/2	137 7/16	111	8 9/16	8 3/8	4 3/4	7	6 3/8	2	5	3	3 1/2	118	1	1 1/2	5/8 x 7/8	6 9/16
04120	4 1/2	137 9/16	111	8 11/16	8 1/2	4 7/8	7	7 3/8	2	6	4	4	118	1 1/2	2	5/8 x 7/8	6 9/16
05120	5 9/16	140 3/16	111	9 3/16	9	5 1/2	7 1/2	8 1/2	2	7	5	4 1/2	118	1 1/2	2 1/2	5/8 x 7/8	6 9/16
06120	6 5/8	137 15/16	110 1/2	8 7/8	8 11/16	4 15/16	5 11/16	9	2	8	6 1/2	5	117	2	3	5/8 x 7/8	
08120	8 5/8	140 15/16	109	10 3/8	10 3/16	5 11/16	9	11 1/2	2	10	6 1/2	6	115	3	4	5/8 x 7/8	
10120	10 3/4	145 3/16	108	11 7/8	11 11/16	6 13/16	10	13 3/4	2 1/4	12 1/2	8	7	113	4	6	3/4 x 1	
12120	12 3/4	145 9/16	105 1/2	13 1/16	13 1/8	6 5/16	11	15 3/4	2 1/4	14 1/2	10	8 1/4	113	6	6	3/4 x 1	
14120	14	150 11/16	103	15 9/16	15 5/8	8 1/4	13	17	2 1/2	16	11	9 1/2	110	8	8	3/4 x 1 1/4	
16120	16	150 15/16	102 7/8	15 9/16	15 3/4	8 3/8	14	19	2 1/2	18	12	10 1/2	110	8	8	3/4 x 1 1/4	
18120	18	153 11/16	102 3/4	16 3/16	16 1/2	9 1/8	15	21	5 3/4	14	11	12 1/2	108	8	8	7/8	
20120	20	153 3/16	103 1/4	16 1/16	16 1/8	8 7/8	16	23	5 3/4	14 1/2	11 1/2	13 1/2	109	8	8	7/8	
22120	22	153 3/16	101 3/4	16 13/16	16 7/8	9 3/16	17	25	5 3/4	15	12	14 1/2	109	8	8	7/8	
24120	24	158 5/16	101	17 1/16	17 3/8	10 7/16	18	27	5 3/4	15 1/2	12 1/2	15 1/2	107	8	10	7/8	
25120	25 3/4	160 1/2	99 3/4	19 1/4	19 3/8	11 1/16	19	29 1/4	5 3/4	16	13	16 1/2	105	10	10	7/8	
27120	27 3/4	162 1/2	98 7/8	20 1/8	20 3/8	11 9/16	20	31 1/4	5 3/4	17	14	17 1/2	104	10	10	7/8	
29120	29 3/4	166 5/8	98 1/4	21 3/8	21 3/4	12 5/8	21	33 1/4	5 3/4	18	15	18 1/2	102	10	12	7/8	
31120	31 3/4	166 3/4	97 1/4	21 7/8	22 1/4	12 11/16	22	35 1/4	5 3/4	19	16	19 1/2	102	10	12	7/8	
33120	33 3/4	173	92 7/8	25 7/8	26 1/8	14 7/16	23	37 1/4	5 3/4	22	18 1/2	20 1/2	99	12	14	1	
35120	35 3/4	173	91 1/8	26 1/4	26 7/8	14 3/8	24	39 1/4	5 3/4	23	19 1/2	21 1/2	99	12	14	1	
37120	37 3/4	174 1/16	89 1/2	27 3/16	26	14 11/16	25	41 3/8	5 3/4	24	20 1/2	22 1/2	98	14	14	1	
39120	39 3/4	180 5/16	88 3/4	29 1/16	29 7/8	16 5/16	26	43 3/8	5 3/4	25	21 1/2	23 1/2	95	14	16	1	
42120	43	182 1/2	86 1/8	30 3/4	31 3/4	16 15/16	28	46 1/2	5 3/4	26	22 1/2	25	94	16	16	1	

Dimensions are in inches unless specified otherwise. Catalog dimensions are subject to variations. Use only certified drawings for construction.

Using the Dimension Chart

Dimension chart shows common dimensions with 120" tube length. You must adjust any length dimensions accordingly for your model.

Example: Dimensional adjustments for a model 10144-1 pass with steel channels would be as follows:

B (overall length) – 11' 6 3/16" + 2' 0" = 13' 6 3/16"

C (nozzle ctr-to-ctr) – 9' 0" + 2' 0" = 11' 0"

Q (bundle removal) – 9' 5" + 2' 0" = 11' 5"

Two Pass Type OP Heat Exchangers

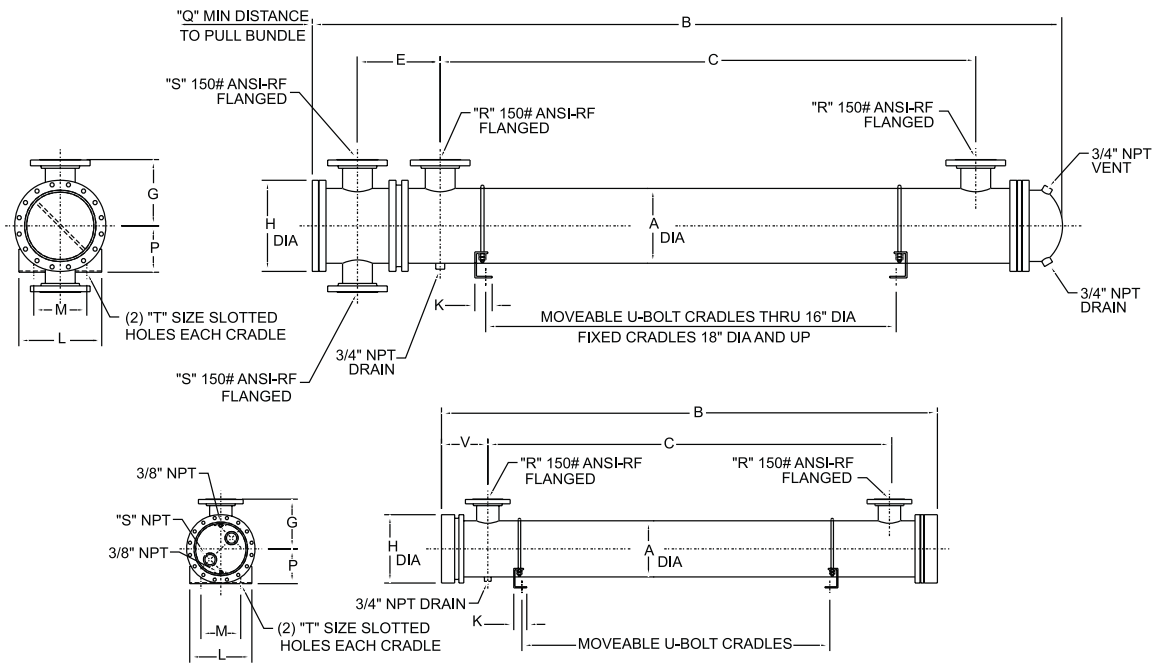

Model	A	B	C	D	E	F	G	H	K	L	M	p	Q	R	s	T	V
03120	3 1/2	129	111	5 7/8	7 7/8	4 1/4	7	6 3/8	2	5	3	3 1/2	118	1	1	5/8 x 7/8	6 9/16
04120	4 1/2	130 1/2	111	6 1/8	8 1/2	4 7/8	7	7 3/8	2	6	4	4	118	1 1/2	1 1/2	5/8 x 7/8	6 9/16
05120	5 9/16	131 1/4	111	6 3/4	8 1/2	5 1/2	7 1/2	8 1/2	2	7	5	4 1/2	118	1 1/2	1 1/2	5/8 x 7/8	6 9/16
06120	6 5/8	132 15/16	110 1/2	8 13/16	8 11/16	4 15/16	8	9 1/2	2	8	6 1/2	5	117	2	2	5/8 x 7/8	
08120	8 5/8	135 1/16	109	10 3/16	10 3/16	5 11/16	9	11 1/2	2	10	6 1/2	6	115	3	3	5/8 x 7/8	
10120	10 3/4	138 3/16	108	11 11/16	11 11/16	6 19/16	10	13 3/4	2 1/4	12 1/2	8	7	113	4	4	3/4 x 1	
12120	12 3/4	139	105 1/2	13 7/16	13 1/8	6 15/16	11	15 3/4	2 1/4	14 1/2	10	8 1/4	113	6	4	3/4 x 1	
14120	14	142 1/16	103	15 3/16	15 5/8	8 1/4	13	17	2 1/2	16	11	9 1/2	110	8	6	3/4 x 1 1/4	
16120	16	142 13/16	102 7/8	15 3/16	15 3/4	8 3/8	14	19	2 1/2	18	12	10 1/2	110	8	6	3/4 x 1 1/4	
18120	18	144 11/16	102 3/4	16 3/16	16 1/2	9 1/8	15	21	5 3/4	14	11	12 1/2	108	8	6	7/8	
20120	20	144 5/8	103 1/4	16 3/8	16 1/8	8 7/8	16	23	5 3/4	14 1/2	11 1/2	13 1/2	109	8	8	7/8	
22120	22	145 7/16	101 3/4	17 5/8	16 7/8	9 9/16	17	25	5 3/4	15	12	14 1/2	109	8	8	7/8	
24120	24	148 3/16	101	17 3/8	17 3/8	10 7/16	18	27	5 3/4	15 1/2	12 1/2	15 1/2	107	8	10	7/8	
25120	25 3/4	149 7/8	99 3/4	19 11/16	19 3/8	11 1/16	19	29 1/4	5 3/4	16	13	16 1/2	105	10	10	7/8	
27120	27 3/4	151 1/2	98 7/8	20 1/16	20 3/8	11 9/16	20	31 1/4	5 3/4	17	14	17 1/2	104	10	10	7/8	
29120	29 3/4	153 7/8	98 1/4	21 1/4	21 3/4	12 5/8	21	33 1/4	5 3/4	18	15	18 1/2	102	10	12	7/8	
31120	31 3/4	154 1/2	97 1/4	22 5/16	22 1/4	12 11/16	22	35 1/4	5 3/4	19	16	19 1/2	102	10	12	7/8	
33120	33 3/4	158 1/16	92 7/8	24 3/4	26 1/8	14 5/16	23	37 1/4	5 3/4	22	18 1/2	20 1/2	99	12	14	1	
35120	35 3/4	158 1/2	91 1/8	26 1/8	26 7/8	14 3/8	24	39 1/4	5 3/4	23	19 1/2	21 1/2	99	12	14	1	
37120	37 3/4	159 1/2	89 1/2	27 3/16	26	14 11/16	25	41 3/8	5 3/4	24	20 1/2	22 1/2	98	14	14	1	
39120	39 3/4	161 5/16	88 3/4	28 3/8	29 7/8	16 5/16	26	43 3/8	5 3/4	25	21 1/2	23 1/2	95	14	14	1	
42120	43	165 3/8	86 1/8	30 9/16	31 3/4	16 15/16	28	46 1/2	5 3/4	26	22 1/2	25	94	16	16	1	

Dimensions are in inches unless specified otherwise. Catalog dimensions are subject to variations. Use only certified drawings for construction.

Using the Dimension Chart

Dimension chart shows common dimensions with 120" tube length. You must adjust any length dimensions accordingly for your model.

Example: Dimensional adjustments for a model 10144-1 pass with steel channels would be as follows:

B (overall length) – 11' 6 3/16" + 2' 0" = 13' 6 3/16"

C (nozzle ctr-to-ctr) – 9' 0" + 2' 0" = 11' 0"

Q (bundle removal) – 9' 5" + 2' 0" = 11' 5"

Heat transfer performance to the highest degree.

We have a heritage of more than 140 years designing and delivering world-class heat transfer products for nearly every industry application. With a global network of manufacturing facilities and regional sales offices throughout the world, we are ready to serve. Our market-focused approach enables us to work closely with you during every step of the process. The result? Value-added, custom-engineered solutions that help ensure your success.

There's heat transfer. And then there's API Heat Transfer.



"What differentiates API Heat Transfer is the knowledge of the product—of our product and their product. When you want a heat exchanger, you go to API Heat Transfer."

– Specifying Design Engineer

See how our performance can improve yours.

Contact your API Heat Transfer sales rep or visit apiheattransfer.com today.

USA

Buffalo Facility

Global Headquarters
2777 Walden Avenue
Buffalo, NY 14225, USA
+1.716.684.6700

Arcade Facility

91 North Street
Arcade, NY 14009, USA
+1.585.496.5755

Franklin Facility

4700 Ironwood Drive
Franklin, WI 53132, USA
+1.414.761.4500

Iron Ridge Facility

1025 Industrial Road
Iron Ridge, WI 53035, USA
+1.920.387.4200

Racine Facility

5215 21st Street
Racine, WI 53406, USA
+1.262.554.8330

GERMANY

Bretten Facility

Langenmorgen 4
75015 Bretten, Germany
+49.7252.53.0

Dortmund Facility

Breisenbachstrasse 87
44357 Dortmund, Germany
+49.231.9920.119

CHINA

Suzhou Facilities

Building 1

156 Qingqiu Street, 3rd District
Suzhou Industrial Park
Suzhou, Jiangsu 215126, China
+86.512.8816.8000

Building 2

126 Qingqiu Street, 3rd District
Suzhou Industrial Park
Suzhou, Jiangsu 215126, China
+86.512.8816.8000