

Temperature Sensors

Normally Open (Closed on temperature rise)

Contact Rating

6 AMPS AT 120 VAC
 4 AMPS AT 240 VAC

Voltage

0.1 to 240 volts AC or 12 VDC
 8 AMPS, 24 VDC 4 AMPS

Pressure

1,000 PSI operating

Material

303 Stainless Steel Housing

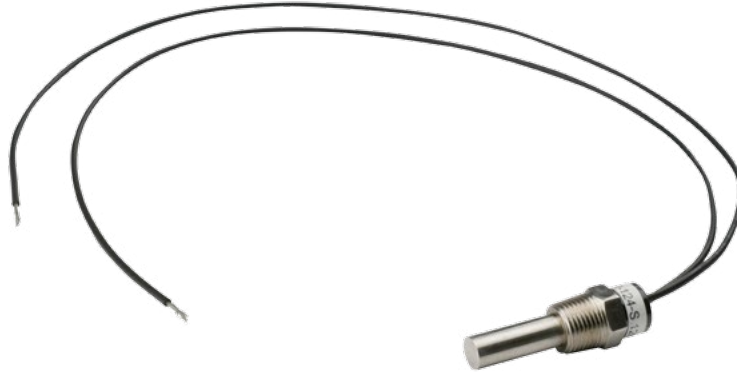

Part Number	Set Temperature (°F)
65769	140
65769	120

*Switching temperature ranges from one (1) to six (6) °F.
 Other temperature settings are available. Consult factory for options.
 For DC applications, do NOT wire directly to motor. (Relay needed.)

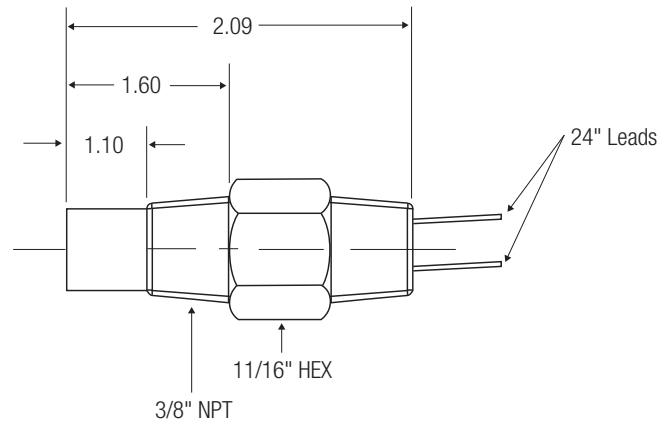

How to Order Consult factory for pricing and lead time

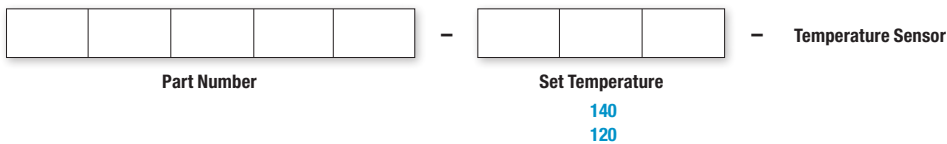

All shipments FOB Racine, WI USA

Thermal Bypass Assembly

This thermal bypass valve is ideally suited for hydrostatic drive circuits which require fast warm-up, controlled fluid temperature, and low return line back pressure. When installed in the return line of a hydraulic circuit that employs an oil cooler, this device will modulate fluid temperature by either shifting return line flow through the cooler, or bypassing directly to the reservoir. In addition, a built-in pressure relief function automatically relieves excess pressure to the reservoir should the cooler become restricted and resultant pressure drop become too high for the cooler circuit.

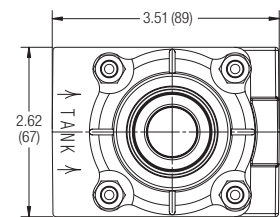
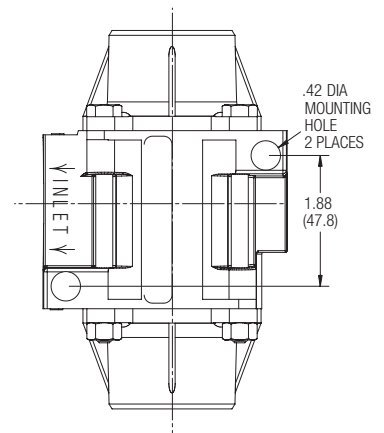
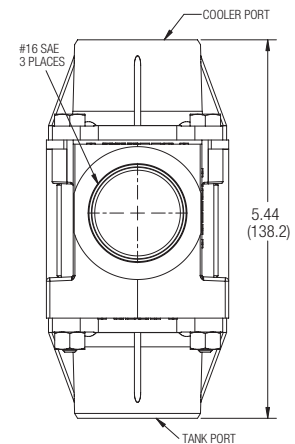

Standard Shift Temperatures

100°F (38°C) 120°F (49°C) 140°F (60°C) 160°F (71°C)

Full Shift (Cooler Port Open) Temperatures

Shift temperature plus 25°F (14°C)

Relief Valve Setting 65 PSI (4.5 BAR) *Consult factory for other pressure settings.*

Maximum Operating Pressure 250 PSI (17 BAR)

Proof Pressure 300 PSI (21 BAR)

Minimum Burst Pressure

Up to the full shift temperature: 325 PSI (22 BAR).

Above the full shift temperature: 600 PSI (41 BAR).

Minimum Operating Temperature -30°F (-34°C)

Maximum Operating Temperature Shift temperature plus 75°F (24°C)

Maximum Flow Rating 60 GPM (227 l/m)

Leakage @ 250 PSI (17 BAR) and 60 GPM (227 l/m) Inlet Flow

Cooler Port:

- 0.5 GPM (2 l/m) maximum up to 5°F (3°C) before shift temp.
- 1.0 GPM (4 l/m) maximum from 5°F (3°C) before shift to shift.

Tank Port: 0.10 GPM (0.4 l/m) maximum

Operating Fluid Mineral base hydraulic fluids

Construction Aluminum die-cast housing

Operating Characteristics

- Mode 1: At temperatures below the shift temperature oil flows from inlet to tank port.
- Mode 2: At temperatures between the start of shift and full shift the flow from the inlet port is divided between the cooler and tank ports.
- Mode 3: At temperatures above the full shift temperature inlet flow is through the cooler port.
- Mode 4: At temperatures above the full shift temperature the excess pressure is relieved through the tank port.

For 120°F Shift Temperature

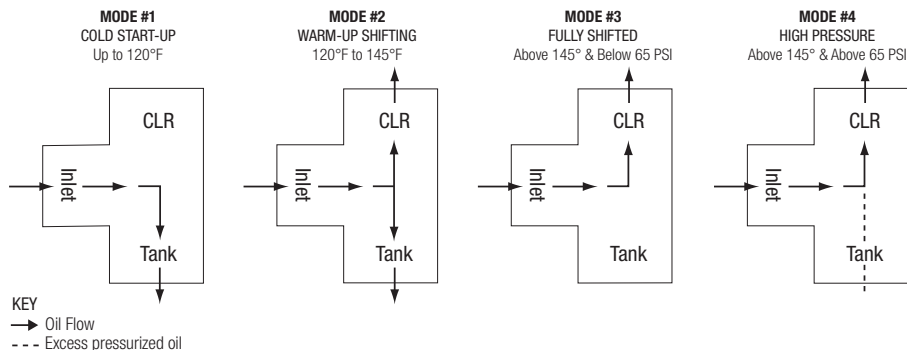

NOTE: If the temperature drops below 145°F the valve will shift back to modes 2 or 1.

Graphic Symbol

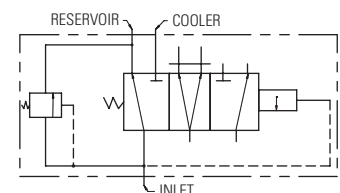

Thermal Bypass Assembly

Pressure Drop (Mobile DTE 26 OIL)

Inlet Port Thru Tank Port
@ 100°F (38°C) (300 SUS)

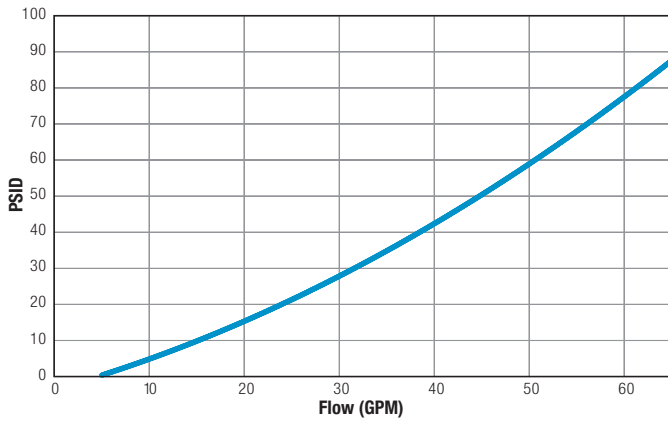

Inlet Port Over Integral Relief Valve
@ 170°F (77°C) (78 SUS)

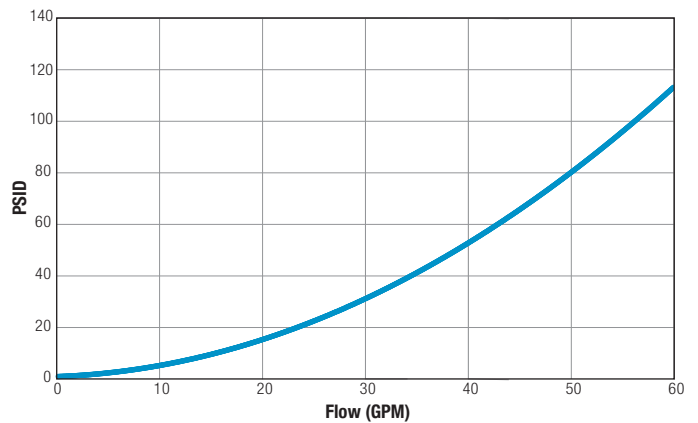

Inlet Port Thru Cooler Port
@ 145°F (63°C) (110 SUS)

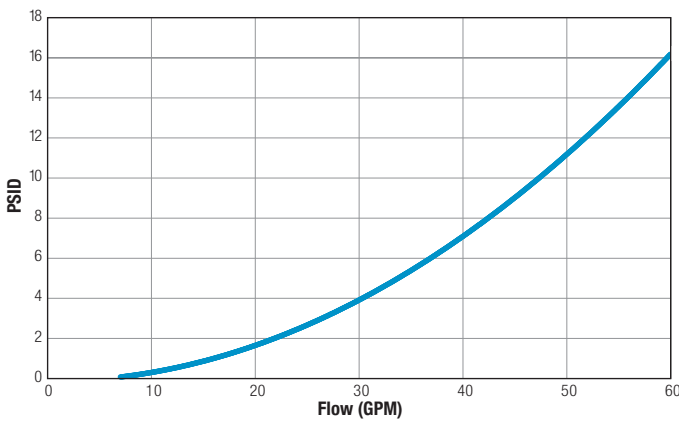

NOTE: Pressure drop shown is added to relief valve crack pressure for total pressure drop.

Part Number	Shift Temperature
65654	100°F (38°C)
65655	120°F (49°C)
65656	140°F (60°C)
65657	160°F (71°C)

How to Order Consult factory for pricing and lead time

- - Thermal Bypass Assembly

Part Number

Pressure Setting
65 = Standard, 65 PSI
Optional pressure settings available in 5 PSI increments, up to 85 PSI.

Three-Way Thermostatic Valves

1/2", 3/4", 1", 1 1/2" & 2" NPT Ports*

- Self-contained
- Wide range of temperatures
- Rugged construction
- Non-adjustable
- Heavy duty
- Operate in any position
- Tamper-proof
- Replaceable element
- Compact



Materials

Housing Grey iron (steel or bronze optional)
125 PSI maximum operating pressure

O-Ring Seals Viton (Buna N optional)

*3", 4" and 6" Flange Models also available.

Operation

TTP thermostatic valves use the principle of expanding wax. A self-contained power element activates a stainless steel sliding valve that provides a positive three-way valve action. All temperature settings are factory set. Elements are field replaceable to obtain the same, or a new bypass temperature setting.

On starting, total flow is in the bypass mode. As the fluid temperature rises, some fluid is diverted to the cooling system. As fluid temperature continues to rise, more flow is diverted until the valve is fully stroked. At this point, all the flow is diverted to the cooler. With respect to temperature ranges, the "nominal" temperature represents the "operating temperature."

Valves are acceptable for oil or water service.

Applications

Three Way Thermostatic Valves may be installed for either mixing or diverting modes of operation at the preference of the user. They may be mounted in any plane.

When installed as a mixing valve, it is on the cold side of the application, and mixes hot liquid with cooled liquid to discharge the proper temperature fluid to the process.

When installed as a diverting valve, it is on the hot side of the application, and bypasses the cold liquid allowing the system to warm up, then directs the hot liquid to the cooler.

Temperature settings are nominal. 110°F and 140°F are standard. Other settings are available upon request. The valves begin to "shift" (open) about 10°F below the nominal temperature setting and are fully shifted about 10°F above.

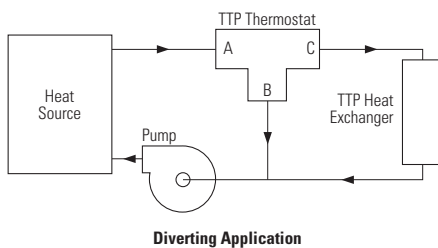
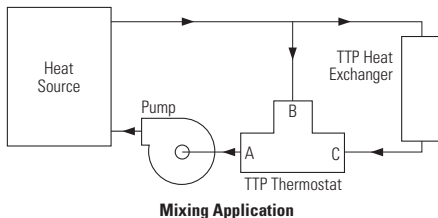

Typical Installation

Hydraulic Power Units Diverting mode 110°F

Air Compressors Mixing mode 140°F

Mobile Oil Coolers Diverting mode 110°F

Radiators Diverting mode 190°F

Three-Way Thermostatic Valves

Pressure Drop Curves

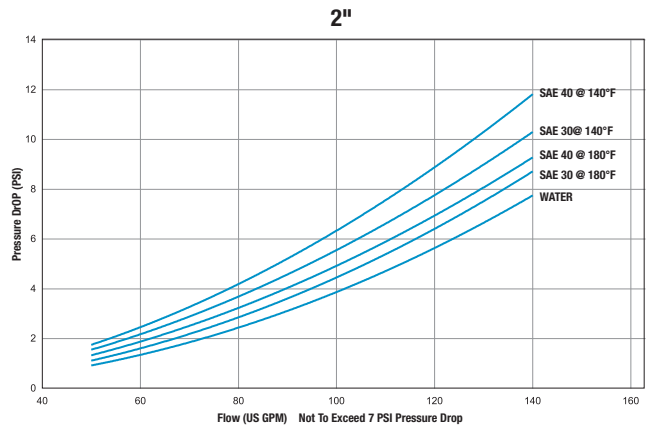
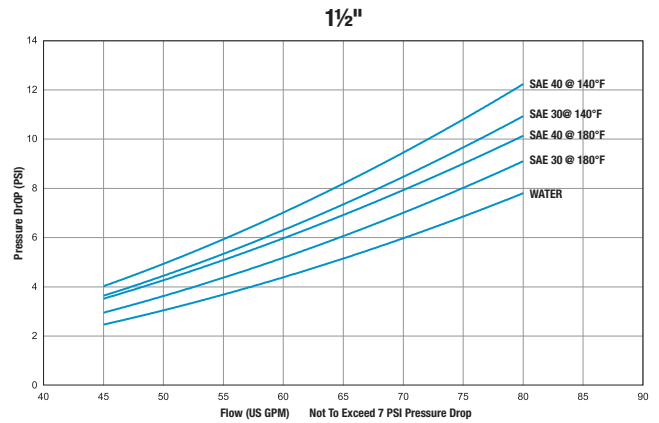
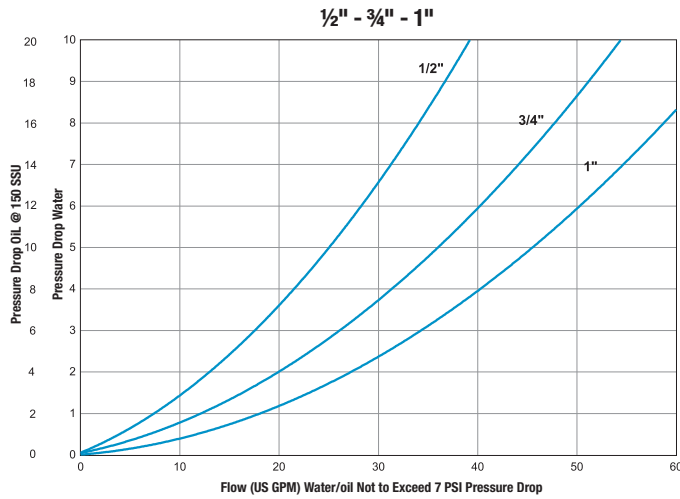

Dimensions and Part Numbers

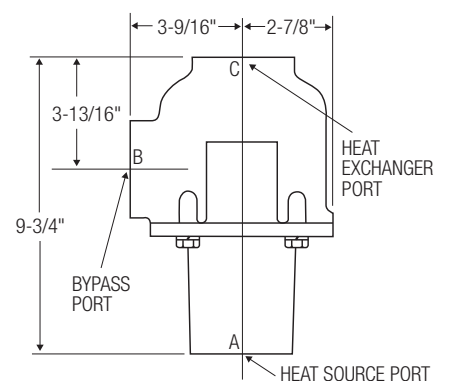
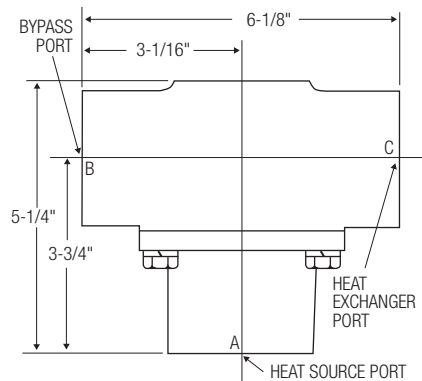
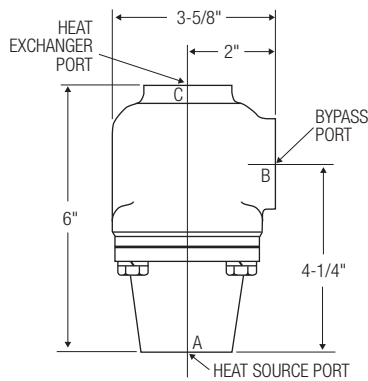

Port Size	Part Number
1/2" NPT	66037-110°F
1/2" NPT	66037-140°F
3/4" NPT	66038-110°F
3/4" NPT	66038-140°F
1" NPT	66039-110°F
1" NPT	66039-140°F
#16 SAE	67365-110°F
#16 SAE	67365-140°F

Port Size	Part Number
1 1/2" NPT	66040-110°F
1 1/2" NPT	66040-140°F
#24 SAE	67760-110°F

Port Size	Part Number
2" NPT	66041-105°F
2" NPT	66041-140°F

NOTE: All three ports on any one valve have the same thread size.

Three-Way Thermostatic Valves

Special Temperature Ranges

½" - ¾" - 1" NPT Part Numbers	1½" NPT Part Numbers	2" NPT Part Numbers
65974	65977	65978
65975	66040	66041
65976	67760	
66037	(#24 SAE)	
66038		
66039		
67365		
(#16 SAE)		

½" - ¾" - 1" NPT		1½" NPT		2" NPT	
Nominal	Temperature Range (°F)	Nominal	Temperature Range (°F)	Nominal	Temperature Range (°F)
80	77-88	80	70-88	75	70-85
90	80-100	90	80-100	90	85-105
110	100-120	110	100-120	105	100-116
120	110-130	120	110-130	120	110-130
130	120-140	130	120-140	130	124-140
140	130-150	140	130-150	140	135-150
150	140-160	150	140-160	150	145-160
160	150-170	160	150-170	155	150-165
170	163-180	170	163-180	160	155-172
185	175-190	175	170-185	165	160-175
195	185-200	180	175-190	170	165-180
200	190-210	190	185-200	180	175-190
		200	190-210	195	188-208
				210	200-215

EXAMPLE: 1" NPT, Part Number 66039-90 indicates the 1" NPT valve with a nominal shift temperature of 90°F. The actual operating temperature range in this example is 80-100°F. The valve begins to open at 80°F, and is fully open at 100°F.

How to Order Consult factory for pricing and lead time

					-				°F
Valve Part Number						Nominal Temperature Setting			